

Enhancing PFAS-Analysis in Solid and Liquid Environmental Matrices - A Fully Automated Approach

Lilit Ispiryan*, Tobias Uber*, Andreas Bruchmann*
 *Trajan Scientific and Medical, Axel Semrau GmbH, 45549 Sprockhövel, Germany.

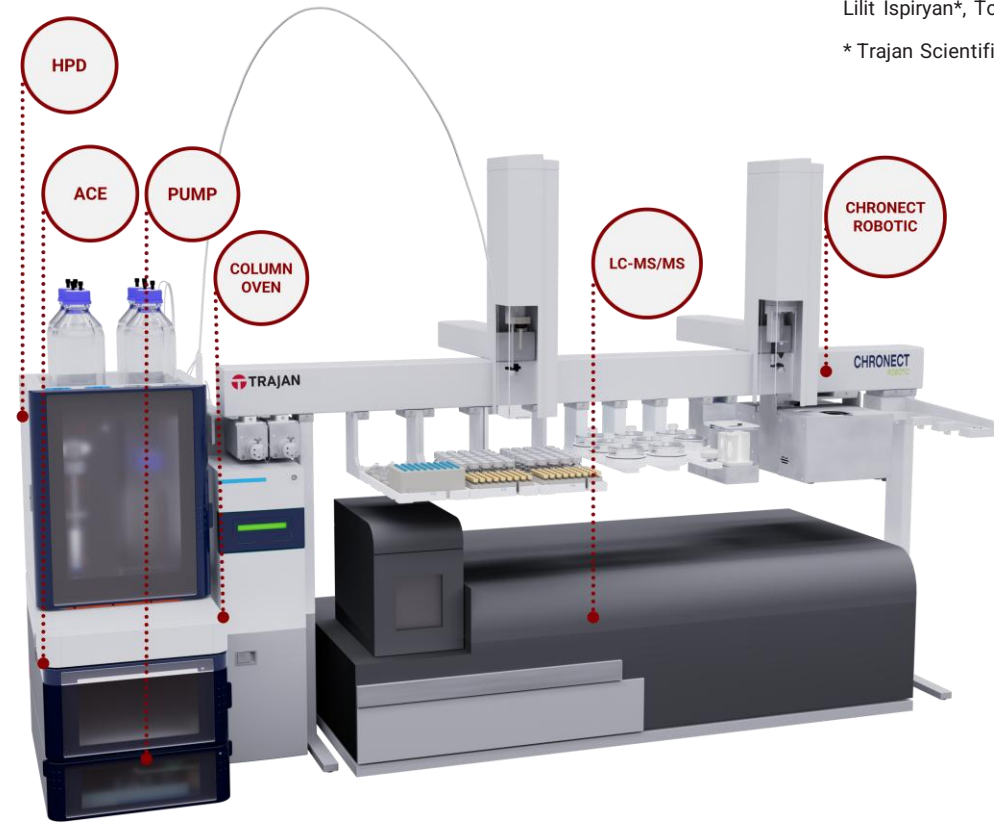

CHRONECT™ Workstation PFAS for automated PFAS analysis

- **Per- and polyfluoroalkyl substances (PFAS)** are a major environmental concern due to their persistence and harmful effects on human health.
- **Analytical challenges:** accurate analysis of PFAS in different, complex matrices is essential but challenging, especially at sub-ppt levels.
- **Limitations of current methods:** increasing injection volumes in analytical systems can compromise analytical quality and risk system fouling. Time-consuming sample preparation is required to purify analytes and remove interfering matrix – essential for achieving ever decreasing target LOD/ LOQ
- **Advantages of Online SPE & Automation:** online SPE with LC-MS allows for large volume injections, analyte enrichment, and matrix removal, enhancing efficiency and reducing manual errors. Miniaturised automated approach, also of preceding solid-liquid extraction of solid matrices, offers economic and ecological advantages over manual methods, eliminating manual handling and lowering risk for error and external contamination.
- **CHRONECT™** is using modular components individually selected for a specific workflow. The CHRONECT™ Workstation PFAS fully automates the analytical procedure of PFAS in solid and liquid environmental samples. It encompasses solid-liquid extraction, loose carbon cleanup, and online SPE LC-MS/MS, the analytical procedures are based on US EPA 1633 and in compliance with DIN 38414-14 and DIN 17892, reaching MDLs between 0.01-0.2 ng/g for soil and 0.1-5 ng/L for water.



CHRONECT ROBOTIC PAL3: 200 cm Dual head PAL

- Automated sample preparation prior to online SPE LC-MS/MS and autosampler for direct and SPE injections.
- Equipped with a variety of tools and modules, that are configured individually to meet the requirements of PFAS analysis.

High-Pressure-Dispenser (HPD)

- Syringe pump connected to ACE and injection valve; delivers solvents and sample through cartridges, elutes the cartridge in peak focusing mode for PFAS analysis.
- Equipped with trap between HPD and injector to remove system and solvent contaminants.

Automated Cartridge Exchanger (ACE)

- Places cartridges in flow path and returns them into tray; 4 high-pressure valves set the flow path.
- Cartridges: weak anion exchanger, ~3 mg sorbent material; in 10x1 mm PEEK housing.

SPH1299 Pump

- Can elute the cartridge depending on flow path setting: in peak focusing mode for PFAS analysis LC gradient merged with cartridge elution flow
- Equipped with trap between pump and injector to remove system and solvent contaminants

Mistral – Column oven

- YMC Triart C18 100 x 3.0 mm ID, 3 µm, 12 nm analytical column and corresponding 50 mm guard column

TripleQuad LCMS (e.g., Shimadzu LCMS 8060NX)

Water: methanolic co-solvation approach combined with online SPE LC-MS/MS

- addition of MeOH to reach 50 % MeOH content, stabilising and resolubilising potential surface-adsorbed analytes, then injection to online SPE LC-MS/MS

Soil: fully automated extraction of soils combined with online SPE LC-MS/MS

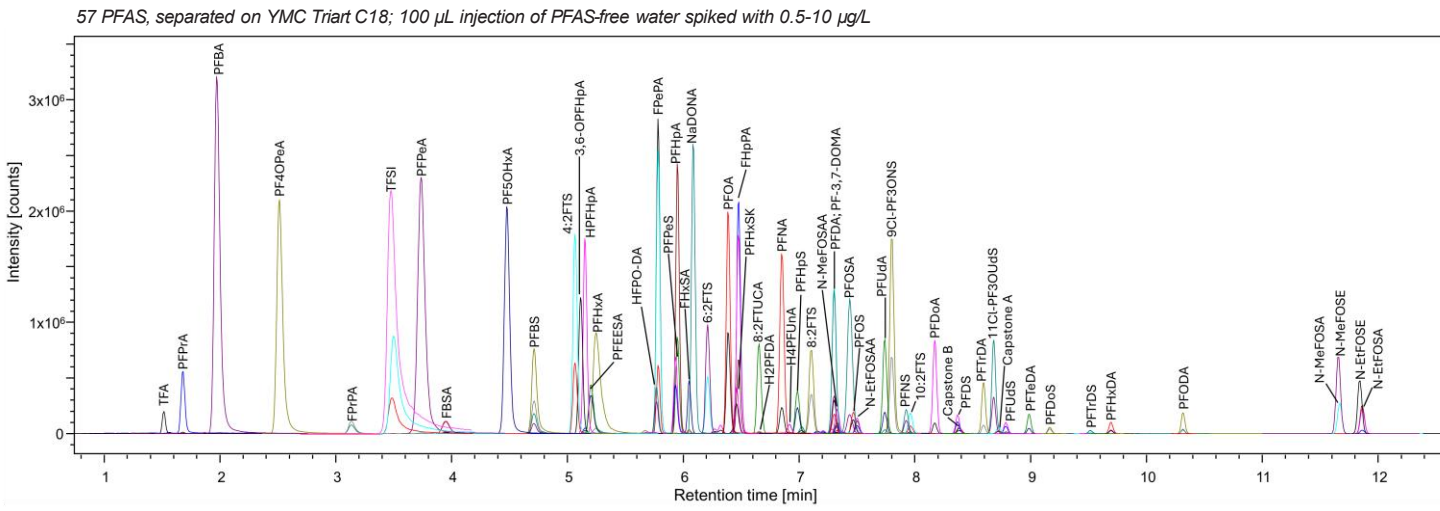
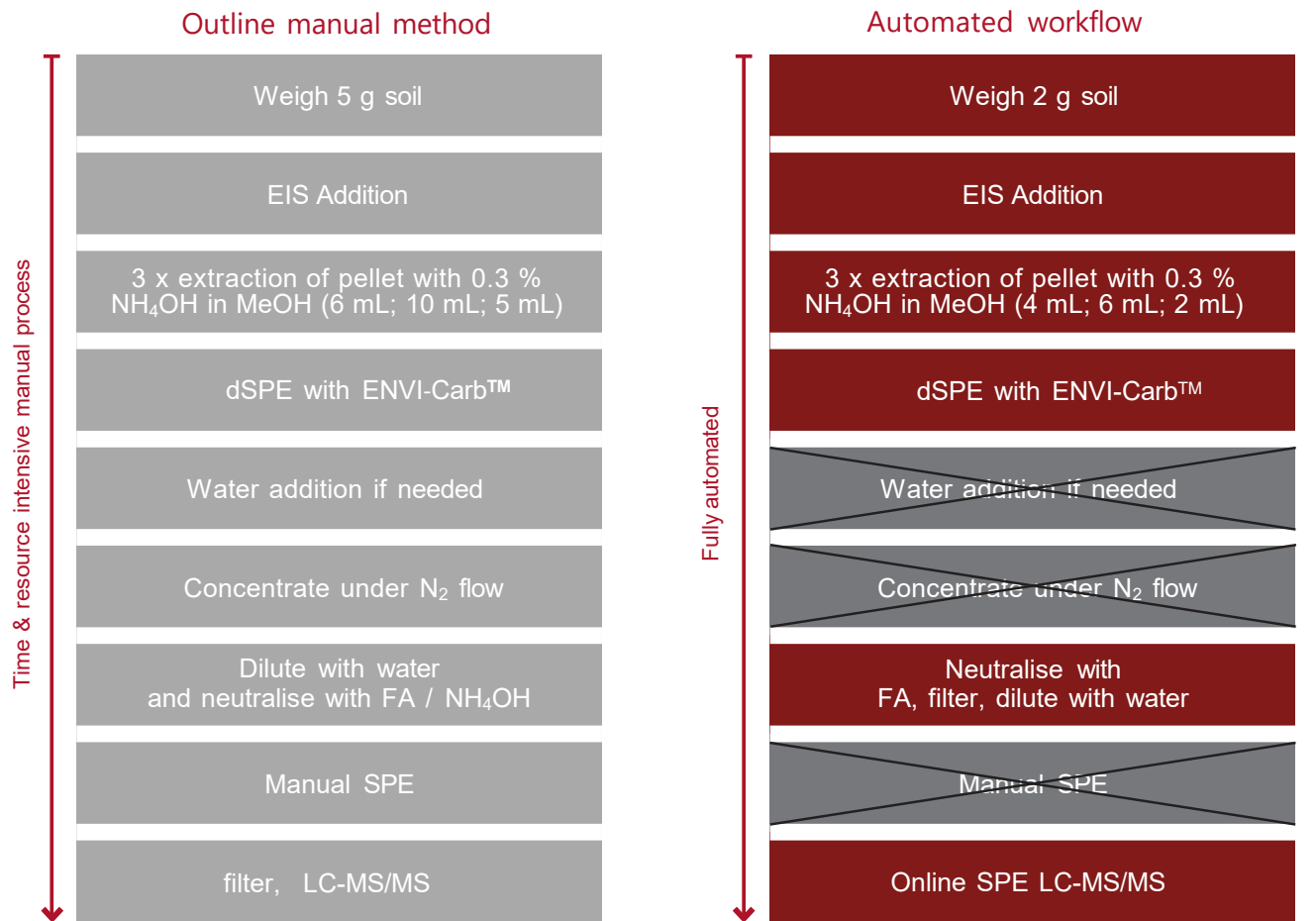

PFOA, PFHxS, PFNA, PFOS in soil matrix (left side); PFAS profile in drinking water, ground water, soil (right side)

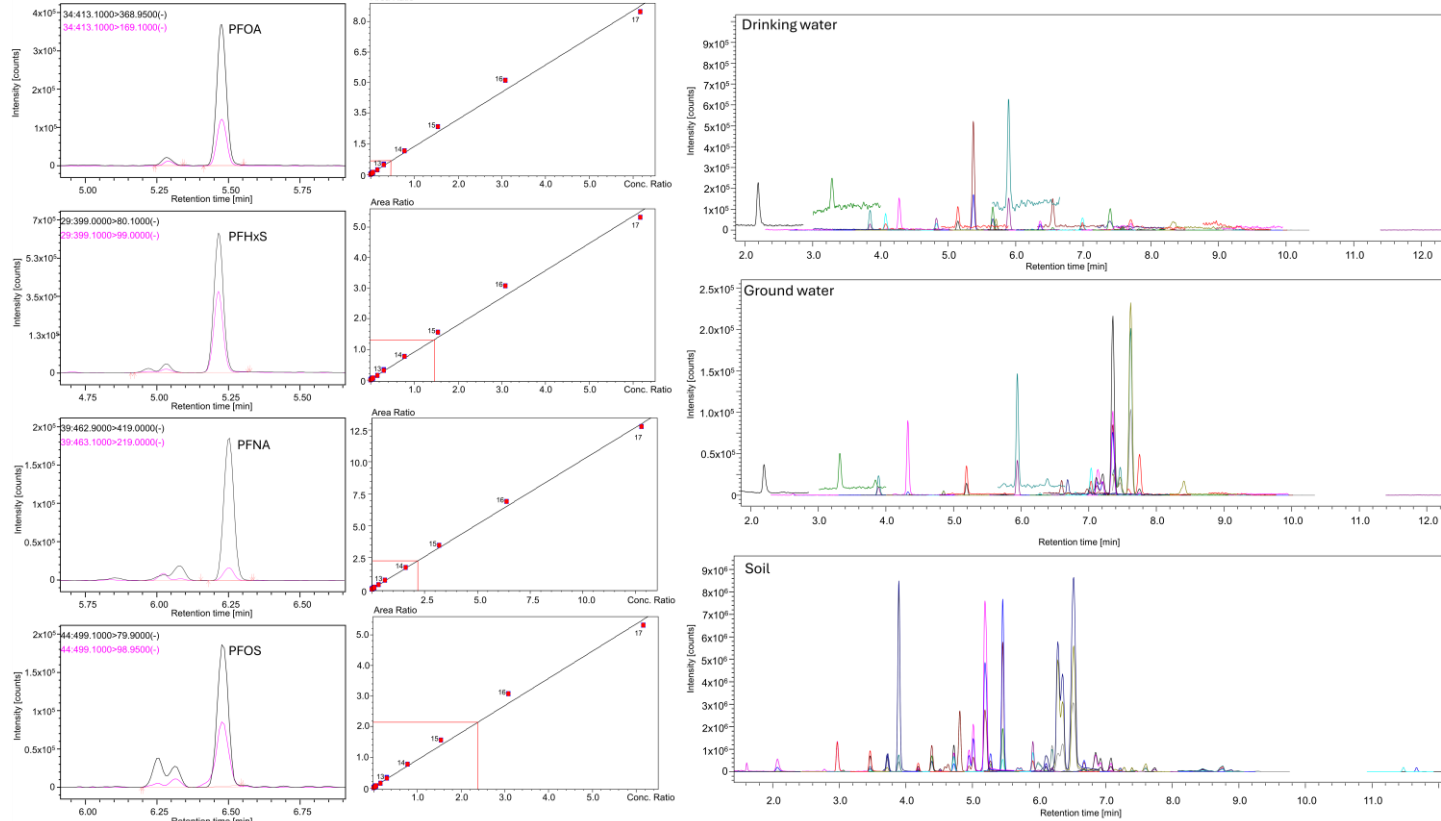

CHRONECT ROBOTIC PAL 3

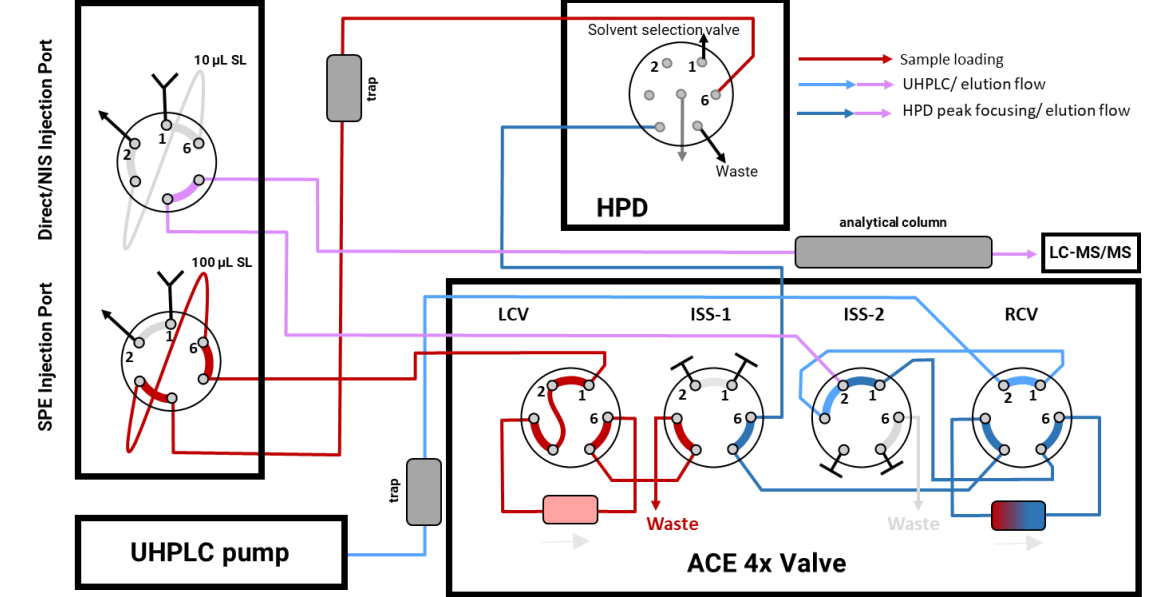

Online SPE

- Cartridge is pre-cleaned, conditioned and equilibrated in left clamp of ACE, sample is loaded into loop on PAL.
- Injection valve switches into inject position and sample is pushed onto cartridge with water through HPD.
- For elution the cartridge is transported to right clamp and HPD starts dispensing 1 % NH₄OH/MeOH for elution in peak focusing mode (elution flow is merged with pump flow in T-rotor seal of ACE valve).
- Analytes are focused on analytical column as they elute from cartridge and start separating with increasing gradient.

Contact info@trajanscimed.com
for further information